

# DEGESCH AMERICA AND PHOSTOXIN<sup>®</sup>

ALUMINUM PHOSPHIDE

protecting stored products all over the world!

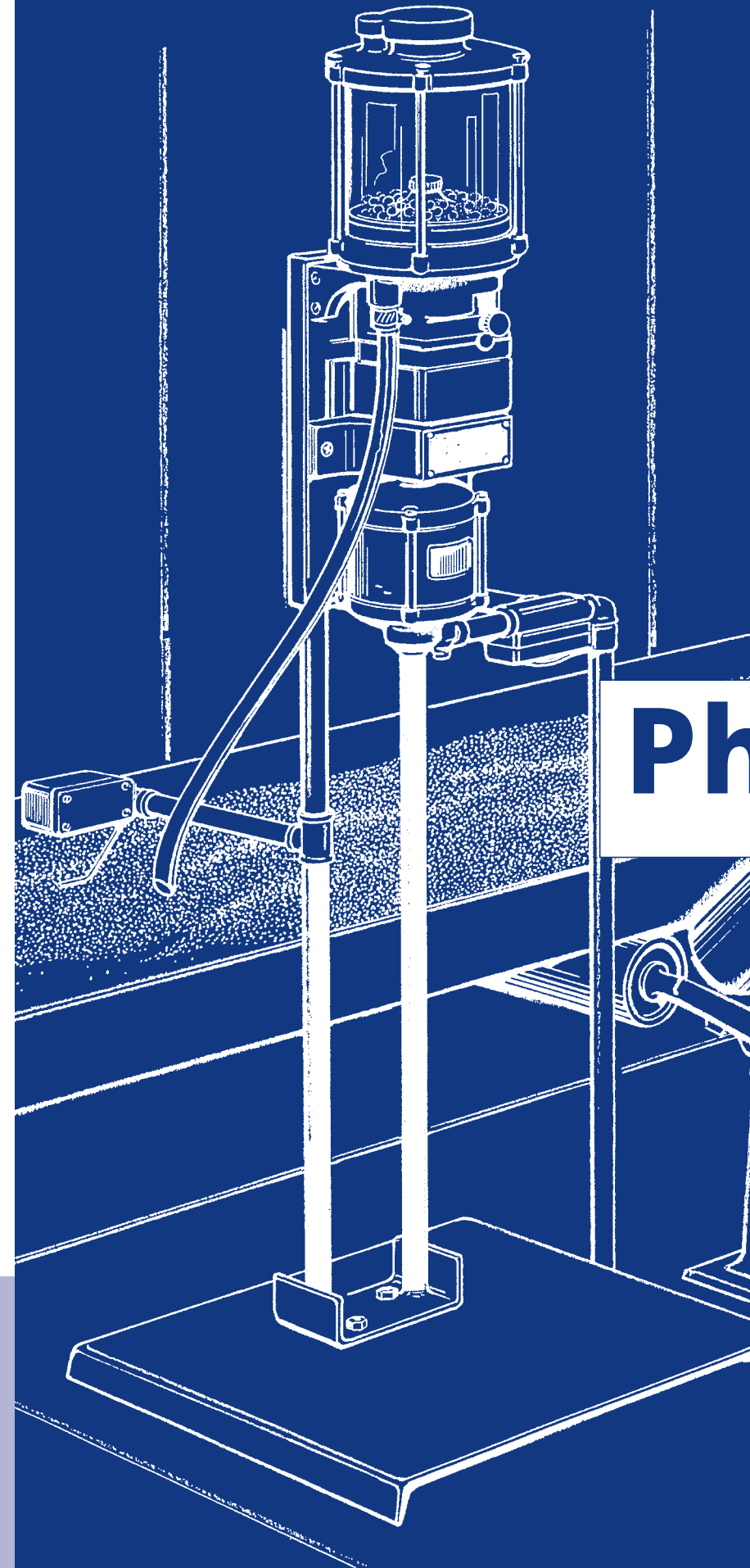
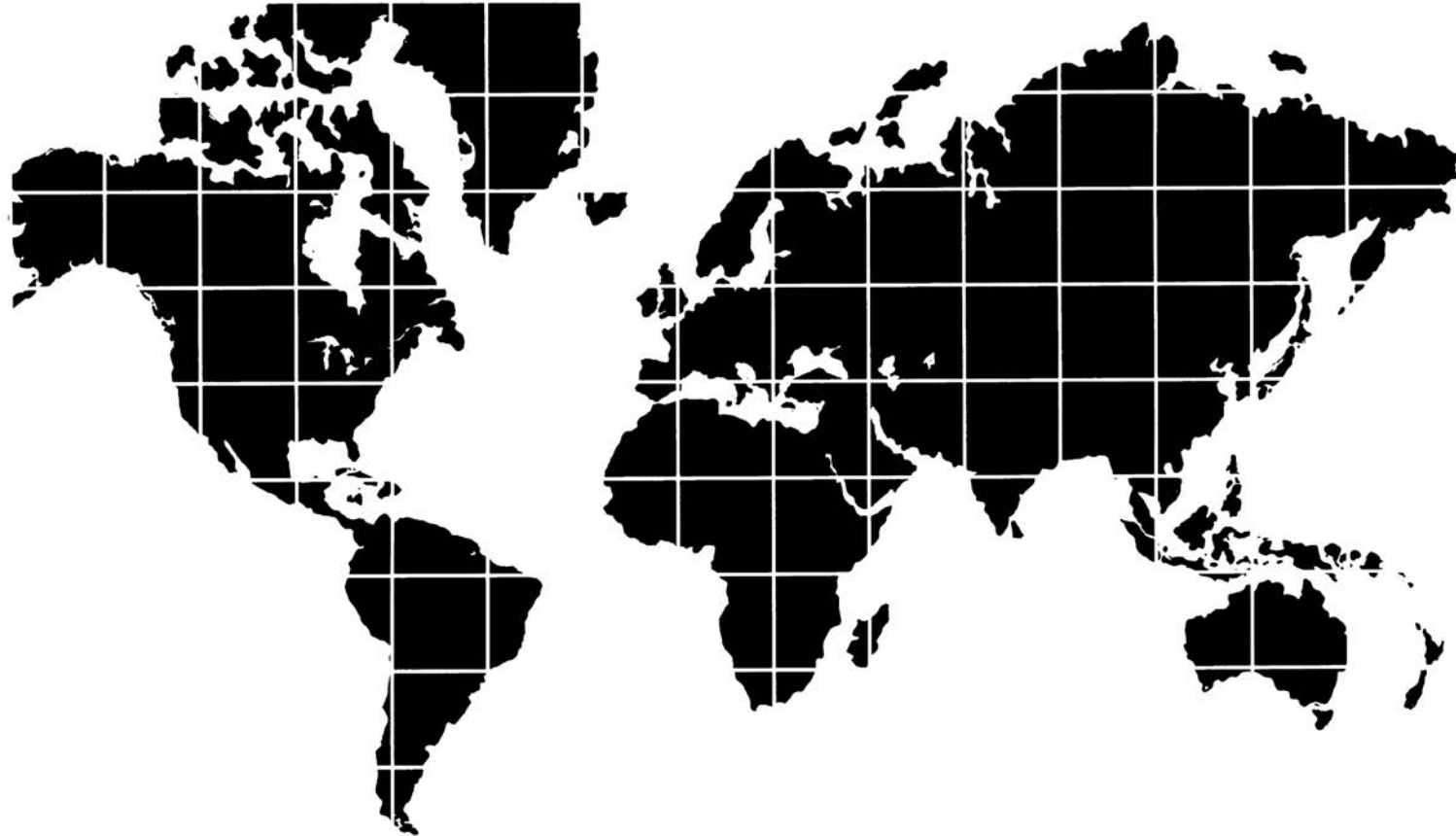

automated  
elevator  
fumigation  
is easy and  
economical  
with the

## Phostoxin<sup>®</sup>

ALUMINUM PHOSPHIDE FUMIGANT

AUTOMATIC  
PELLET  
DISPENSER

DEGESCH AMERICA, INC.  
P.O. BOX 116  
WEYERS CAVE, VIRGINIA 24486  
540-234-9281 • 1-800-330-2525  
Internet: [www.degeschamerica.com](http://www.degeschamerica.com)  
E-mail: [degesch@degeschamerica.com](mailto:degesch@degeschamerica.com)



# Phostoxin®

## FUMIGANT

Nothing protects grain like aluminum phosphide, and there is no finer aluminum phosphide than Phostoxin®

Developed and produced under the direction of Degesch personnel, it has established new standards for purity, consistency and effectiveness. Finely ground aluminum phosphide from the world's richest deposits of aluminum ore is combined with ammonium carbamate and paraffin to form pellets which decompose slowly when exposed to air and thus release hydrogen phosphide gas. This gas actively penetrates the commodity and every area of the storage facility to kill virtually all adult insects, eggs, larvae, and pupae. No harmful residue remains to affect flavor, milling quality or seed germination. PHOSTOXIN® poses no known environmental hazards when proper disposal procedures are followed.



## Maintenance and service...

**THE MOTOR:** The motor is a General Electric Model No. 5KH32ENB168. It is explosion proof, and is a 1/12 horsepower type KH single voltage unit.

**LUBRICATION:** Motors with ball bearings are packed with sufficient grease for approximately five years of operation under normal conditions. If the motor is operated 24 hours per day every day, or under similarly severe conditions, the bearings should be replaced every two or three years.

**THERMAL PROTECTION:** The motor is protected from overheating by an automatic-reset type thermal overload switch. If the motor stops for other than a normal shutoff, it may be due to the operation of this overload switch (Thermo-protector). After cooling, the motor will automatically

restart, assuming there is still electric current reaching it. Precautions should be taken to prevent any hazards to your operation that could result from this automatic restart. If there is no way to prevent such hazards, and you prefer not to use the thermal protection feature, follow the appropriate wiring instructions to by-pass it. (If your motor has only 4 lead wires, it is not equipped with the Thermo-protector).

**ROTATION:** While the motor may normally be reversed in rotation, the transmission will produce counter-clockwise rotation, regardless of the directional input of the motor.

**CARE:** The V-belt should be periodically tightened just enough to prevent belt slippage during operation.

### Single Voltage. Single Speed, CCW/CW Rotation

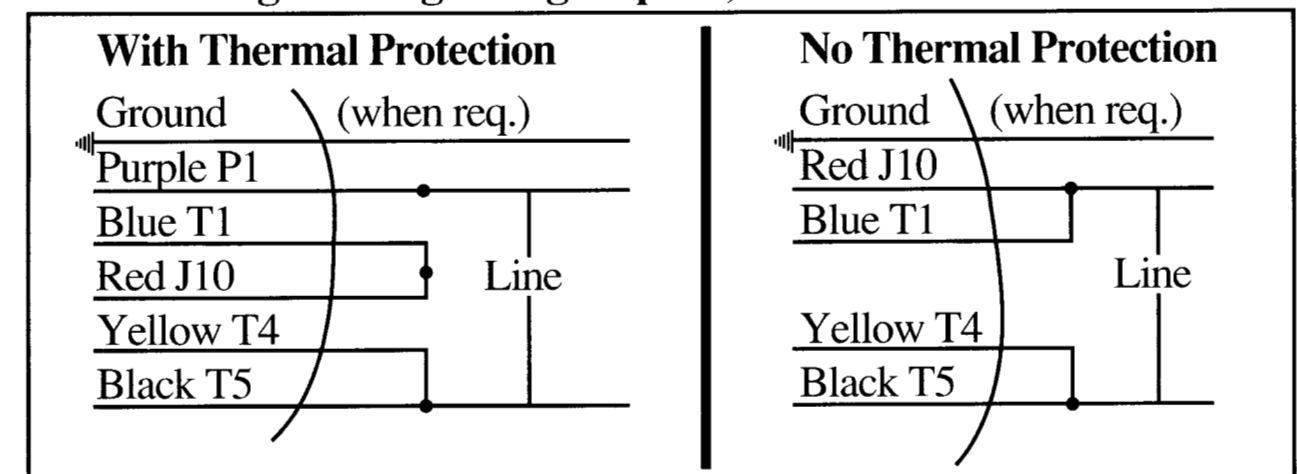

Connections shown are for CCW rotation viewing lead end of motor.  
For CW rotation interchange blue (or T1) and yellow (or T4) leads.  
N.P. 173640

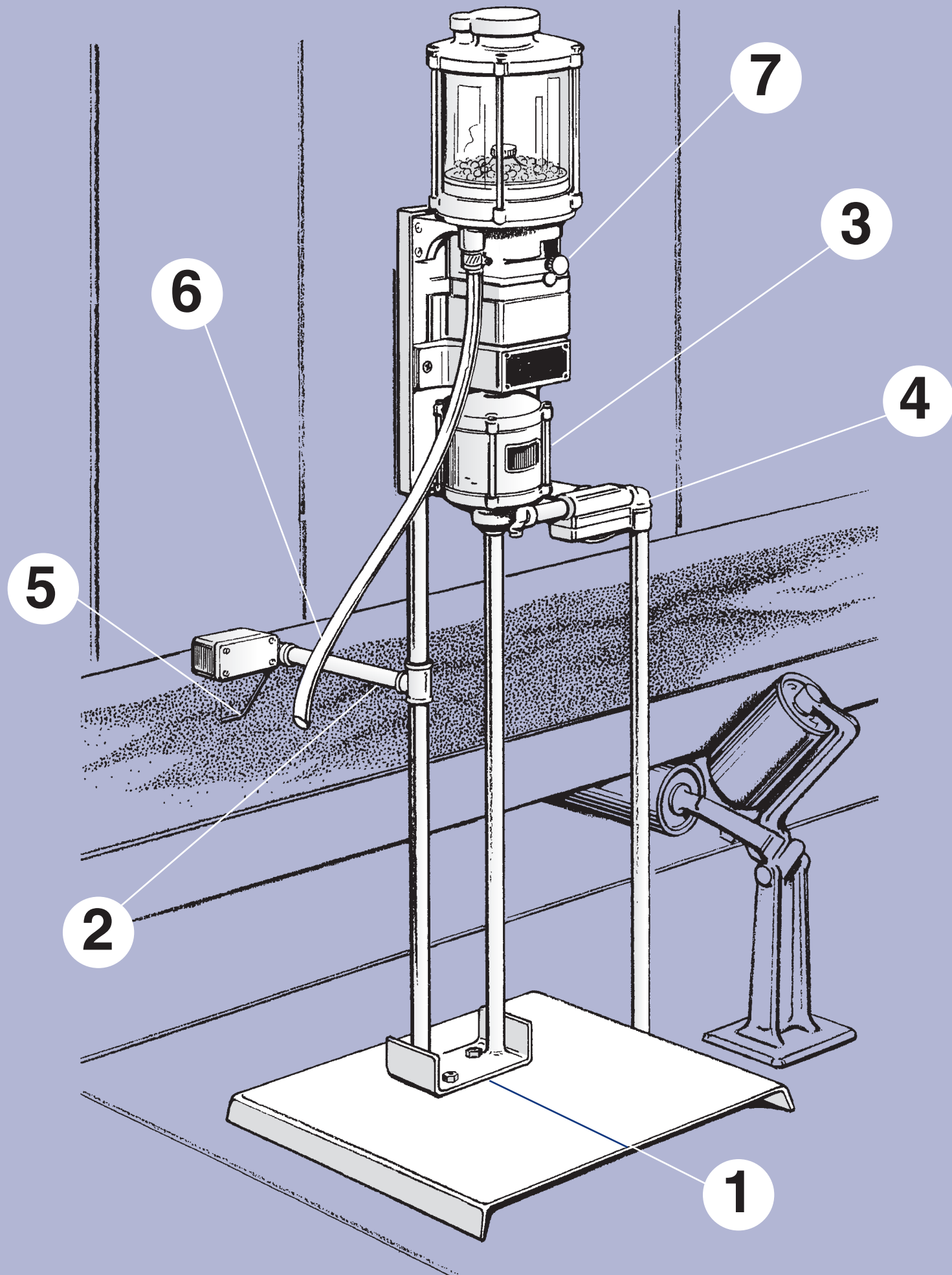

## installation...

The Automatic Pellet Dispenser is easily installed by following the simple instructions below:

- 1** The Dispenser is normally mounted on a metal base which is bolted to the floor next to the conveyor.
- 2** After the base is installed, the extension arm should be attached to it, then adjusted for proper height over the conveyor and locked into position.
- 3** The main dispenser unit should then be mounted to the base and the wiring connections made.
- 4** All electrical components and wiring shall be in compliance with the appropriate local codes. See following pages for further electrical instructions.
- 5** When the Automatic Pellet Dispenser is used over an open conveyor, adjust the flow switch and trip wire so that the dispenser operates **ONLY WHEN GRAIN IS MOVING** on the conveyor.
- 6** With tape or wire, secure the pellet discharge tube to the extension arm in a position that will allow the pellets to fall into the grain moving on the conveyor.
- 7** The dispenser must be properly calibrated to provide a pellet flow rate that is correct for the dosage required. With the four hole plate, the maximum discharge of pellets is 100 per minute, and for the six hole plate, 150 pellets per minute. See the following page for calibration and operating instructions.



**Operation...** After installation, your PHOSTOXIN® Automatic Pellet Dispenser can be calibrated to meet your fumigation needs by considering the following factors:

**1.** The dosage is determined by the tightness of the storage. Refer to the label on the PHOSTOXIN® flasks.

**DOSAGE**



**2.** The speed of the conveyor will determine at what speed your dispenser must drop pellets in order to satisfy your particular dosage requirements.

**TURNING RATE**

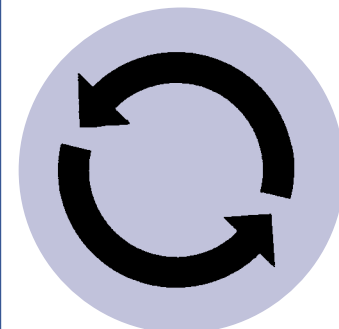

**3.** Dispensing plates are available with either 4 or 6 holes to meet the speed of your particular conveyance.

**CORRECT PLATE**

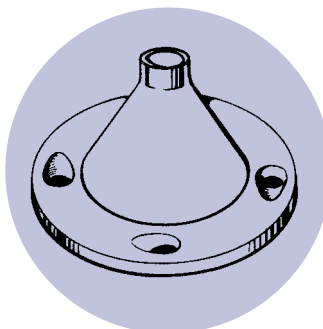

**4.** You can easily time the dispensing rate with the sweep second hand on your watch and adjust the calibration. This setting should then be marked and the adjustment lever locked securely in place.

**CALIBRATION**

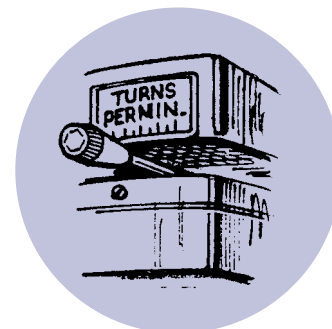

**Safety...** Always keep your PHOSTOXIN® flasks snugly closed, and store them in a cool, dry area. This area should be locked to prevent entry by unauthorized personnel.

Prior to fumigation, carefully read the instructions printed on the machine housing. Always consult your PHOSTOXIN® label for application instructions. All personnel involved in fumigation procedures should be trained by an experienced instructor.

Only enough pellets for one hour of operation should be placed in the hopper. The unit should be checked hourly by the operator and further pellets added as necessary.

Where it is allowed by government officials, all pellets remaining after an application is completed, should be re;turned to an original flask. Loosen the two knurled nuts on the base of the hopper; remove the hopper and invert it over the flask of PHOSTOXIN®. The flask should then be resealed and placed in a suitable, secure pesticide storage area.

**NOTE:** Where laws do not allow resealing of containers, all pellets must be used or disposed of according to regulations.

Warning signs should be attached to the storage area being fumigated. The signs should state the time of the application and the exposure period to be allowed.

**DO NOT use liquid of any kind to clean the unit.**

You can easily and efficiently apply PHOSTOXIN® Fumigant to stored grain with the Automatic Pellet Dispenser. This sturdy, reliable unit will save you time and money, reduce handling, eliminate dosing errors and insure even distribution of the fumigant. It is easy to install and operate, and dosage can be varied as necessary.

In the United States, it is listed for use in hazardous locations by Underwriters Laboratories, Inc.

